

## 116 BEAM CLAMP

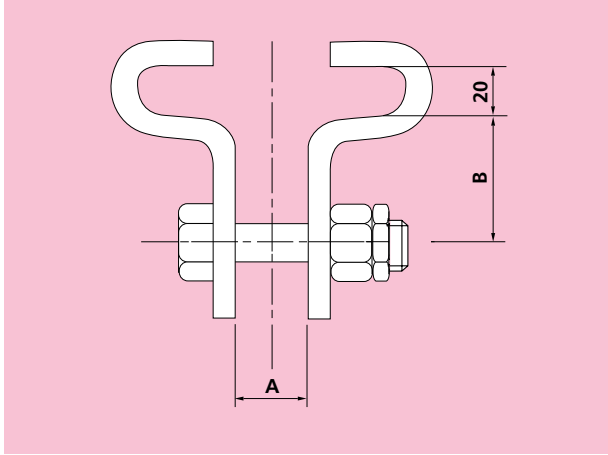

Material: Carbon Steel Order by Part No. & Beam Size

PART No.	FLANGE WIDTH	STEEL SIZE	A	B	BOLT SIZE	LOAD CAPACITY	
						kgf	kN
F116-1	63-152	35x8	10	40	M10	360	3.5
	203 max.	40x10					
F116-2	63-152	40x10	12	40	M12	500	4.9
	203 max.	45x10					
F116-3	63-152	45x10	16	45	M16	650	6.4
	203 max.	60x10					
F116-4	63-178	55x12	20	55	M20	900	8.8
	254 max.	70x12					
F116-5	63-178	70x12	20	65	M20	1200	11.8
	254 max.	60x15					
F116-6	63-178	60x15	20	65	M20	1550	15.2
	254 max.	80x15					

7

8

9

10

11