

238 CLEVIS

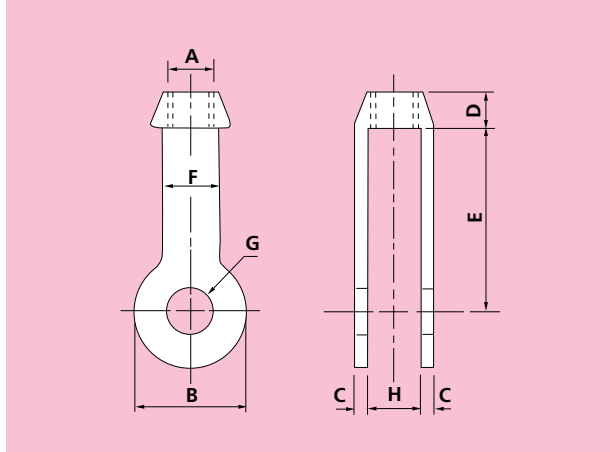

Material: Forged Steel or Carbon Steel
This item may be forged or profiled

PART NUMBER	ROD DIA	A	B	C	D	E	F	G	H	Wt. kgf	LOAD CAPACITY		LOAD GROUP
											kgf	kN	
F238M08	8	38	13	32	95	30	10	18	1.2	230	2.3	0	
F238M10	10	38	13	32	95	30	12	18	1.2	360	3.5	1	
F238M12	12	38	13	32	95	30	14	18	1.1	530	5.2	2	
F238M16	16	38	13	32	95	30	18	18	1.1	1010	9.9	3	
F238M20	20	63	16	32	102	30	22	24	1.8	1580	15.5	4	
F238M24	24	76	18	32	127	38	26	28	2.9	2280	22.4	5	
F238M30	30	76	18	32	127	38	32	28	2.8	3650	35.8	6	
F238M36	36	89	20	41	152	44	38	48	4.6	5340	52.4	7	
F238M42	42	102	22	44	152	50	44	56	6.1	7400	72.6	8	
F238M48	48	127	28	57	178	64	50	58	12.0	9650	94.6	9	
F238M56	56	152	33	70	203	76	58	75	20.4	13350	130.9	10	
F238M64	64	152	33	70	203	76	66	75	19.6	18000	176.5	11	
F238M72	72	150	38	90	200	150	74	80	41.1	23025	225.8	12	
F238M80	80	180	40	100	200	180	82	90	57.3	28125	275.8	13	

274 CLEVIS PIN

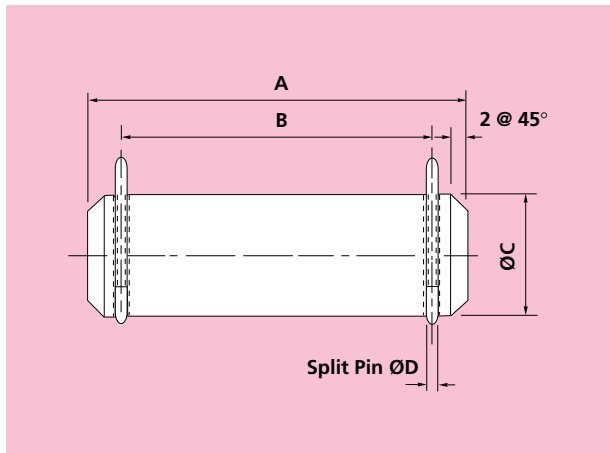

Material: Carbon Steel

PART NUMBER	ROD DIA	A	B	PIN ØC	SPLIT PIN ØD	WEIGHT kgf	LOAD CAPACITY		LOAD GROUP
							kgf	kN	
F274M08	8	70	55	8	4	0.03	230	2.3	0
F274M10	10	70	55	10	5	0.04	360	3.5	1
F274M12	12	75	60	12	5	0.07	530	5.2	2
F274M16	16	75	60	16	5	0.12	1010	9.9	3
F274M20	20	90	75	20	5	0.22	1580	15.5	4
F274M24	24	95	80	24	6	0.34	2280	22.4	5
F274M30	30	105	90	30	6	0.58	3650	35.8	6
F274M36	36	125	110	36	6	1.0	5340	52.4	7
F274M42	42	130	115	42	6	1.4	7400	72.6	8
F274M48	48	150	130	48	8	2.1	9650	94.6	9
F274M56	56	175	155	56	8	3.4	13350	130.9	10
F274M64	64	185	165	64	8	4.7	18000	176.5	11
F274M72	72	205	185	72	8	6.6	23025	225.8	12
F274M80	80	210	190	80	8	8.3	28125	275.8	13

3

4

5

6

7