

281 DUAL FACED ROCKING WASHER

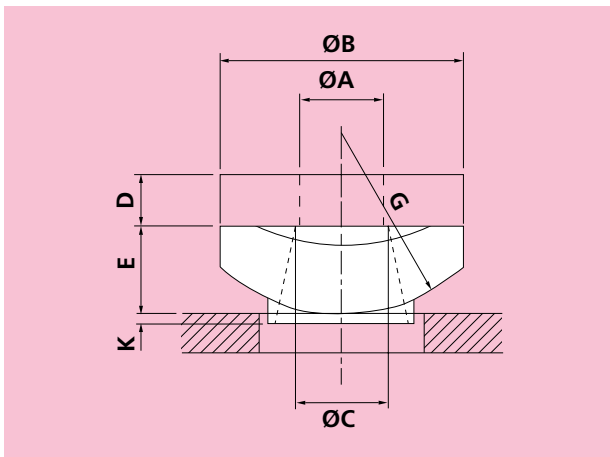

Material: Cast Iron

282 PLATE FOR DUAL FACED ROCKING WASHER

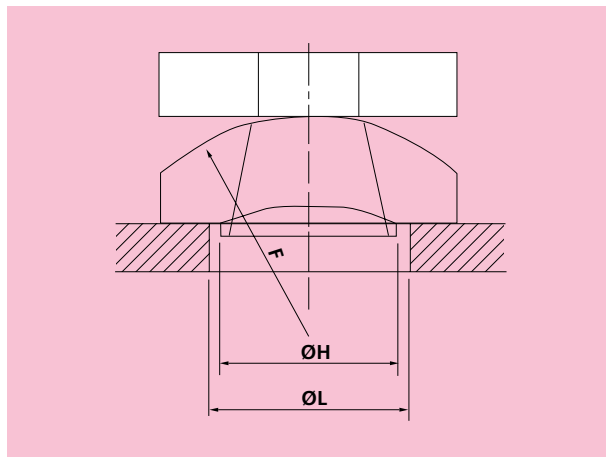

Material: Carbon Steel

PART NUMBER ROCKING WASHER	PART NUMBER PLATE	ROD DIA	A	B	C	D	E	F	G	H	K	L	WEIGHT kgf		LOAD CAPACITY		LOAD GROUP
													ROCKER WASHER	PLATE	kgf	kN	
F281M12	F282M12	M12	13	50	20	10	16	32	32	33	5	38	0.12	0.14	530	5.2	2
F281M16	F282M16	M16	17	50	20	10	16	32	32	33	5	38	0.11	0.14	1010	9.9	3
F281M20	F282M20	M20	21	65	28	15	24	48	48	44	5	49	0.28	0.35	1580	15.5	4
F281M24	F282M24	M24	26	65	28	15	24	48	48	44	5	49	0.26	0.33	2280	22.4	5
F281M30	F282M30	M30	32	98	40	20	36	72	72	59	5	66	0.95	1.1	3650	35.8	6
F281M36	F282M36	M36	38	98	40	20	36	72	72	59	5	66	0.91	1.0	5340	52.4	7
F281M42	F282M42	M42	45	114	46	25	42	84	84	67	6	74	1.4	1.7	7400	72.6	8
F281M48	F282M48	M48	52	130	52	30	48	96	96	75	7	82	2.1	2.6	9650	94.6	9
F281M56	F282M56	M56	60	151	60	35	56	112	112	89	8	93	3.3	4.1	13350	130.9	10
F281M64	F282M64	M64	68	173	69	40	64	128	128	96	10	104	5.0	6.2	18000	176.5	11