

308 CLEVIS HANGER -20°C TO 100°C

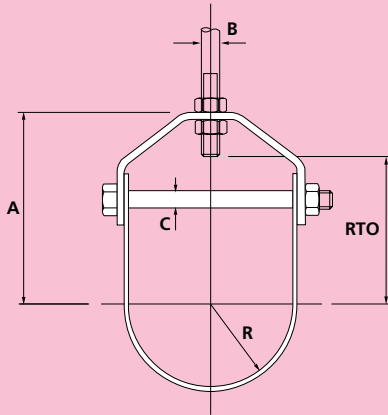

Material: Carbon Steel

PART No.	PIPE NB		A	B	C	R	RTO	TOP STEEL SIZE	BOTTOM STEEL SIZE
	mm	in							
F308-15	15	1/2	60	M6	M6	11.0	39	25x3	25x3
F308-20	20	3/4	64	M6	M6	13.5	42	25x3	25x3
F308-25	25	1	65	M6	M6	17.0	45	25x3	25x3
F308-32	32	1 1/4	72	M10	M10	21.5	50	30x3	30x3
F308-40	40	1 1/2	76	M10	M10	24.5	54	30x3	30x3
F308-50	50	2	79	M10	M10	30.5	58	30x3	30x3
F308-65	65	2 1/2	105	M12	M12	38.0	74	40x5	40x3
F308-80	80	3	115	M12	M12	44.5	82	40x5	40x3
F308-100	100	4	140	M12	M12	57.5	101	40x5	40x3
F308-125	125	5	160	M16	M16	70.0	117	50x6	50x6
F308-150	150	6	183	M16	M16	86.0	137	50x6	50x6
F308-175	175	7	200	M20	M16	99.0	148	50x10	50x6
F308-200	200	8	215	M20	M16	112.0	162	50x10	50x6
F308-250	250	10	255	M20	M20	139.0	197	50x10	50x6
F308-300	300	12	283	M24	M20	165.0	221	50x12	50x10
F308-350	350	14	305	M24	M20	181.0	240	60x12	60x10
F308-400	400	16	336	M24	M24	206.0	270	60x12	60x10
F308-450	450	18	390	M24	M24	232.0	310	80x12	80x10
F308-500	500	20	440	M30	M24	258.0	344	80x15	80x12
F308-600	600	24	495	M30	M24	309.0	397	80x15	80x12
F308-750	750	30	610	M30	M42	385.0	499	80x20	80x12