

349 PIPE BASE LIGHT DUTY MAX. 150 N.B.

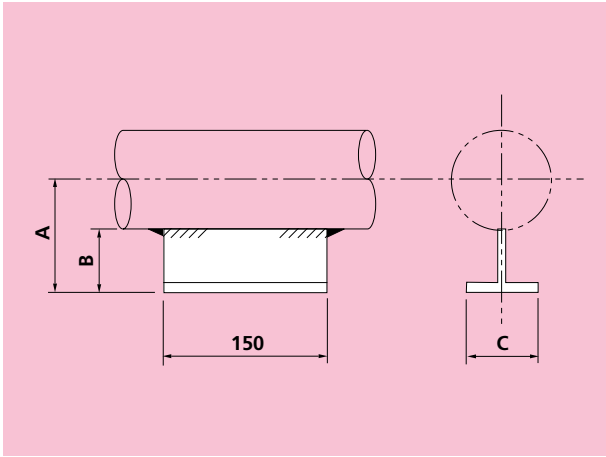

PART No.	PIPE N.B.	A	B	C	LOAD CAPACITY	
					kgf	kN
F349-20	20	76	62	76	150	1.5
F349-25	25	79	62	76	150	1.5
F349-32	32	83	62	76	150	1.5
F349-40	40	86	62	76	150	1.5
F349-50	50	92	62	76	150	1.5
F349-65	65	100	62	76	150	1.5
F349-80	80	106	62	76	150	1.5
F349-100	100	132	75	89	150	1.5
F349-125	125	170	100	102	150	1.5
F349-150	150	184	100	102	150	1.5

Material: Carbon Steel

350 PIPE BASE HEAVY DUTY

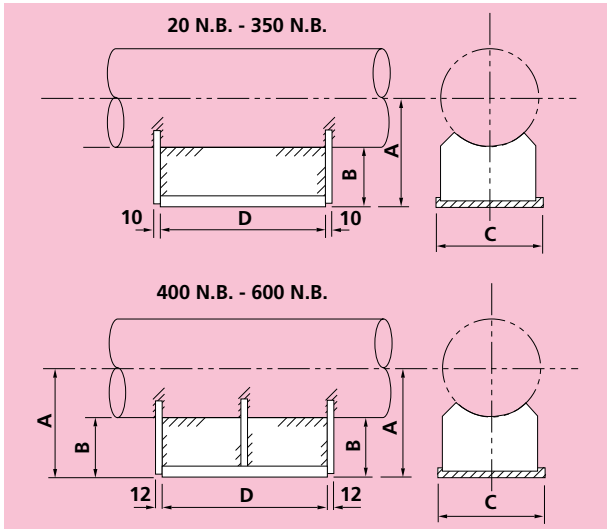

Material: Carbon Steel

PART No.	PIPE N.B.	A	B	C	D	LOAD CAPACITY	
						kgf	kN
F350-20	20	76	62	76	150	1200	11.8
F350-25	25	79	62	76	150	1200	11.8
F350-32	32	83	62	76	150	1200	11.8
F350-40	40	86	62	76	150	1200	11.8
F350-50	50	92	62	76	150	1200	11.8
F350-65	65	100	62	76	150	1200	11.8
F350-80	80	106	62	76	150	1200	11.8
F350-100	100	132	75	89	150	1200	11.8
F350-125	125	170	100	102	150	1200	11.8
F350-150	150	184	100	102	150	1200	11.8
F350-175	175	197	100	203	200	2000	19.6
F350-200	200	210	100	203	200	2000	19.6
F350-225	225	222	100	203	200	2000	19.6
F350-250	250	237	100	203	200	2000	19.6
F350-300	300	262	100	203	200	4000	39.2
F350-350	350	278	100	203	200	4000	39.2
F350-400	400	304	100	203	300	9000	88.3
F350-450	450	329	100	203	300	12000	117.7
F350-500	500	354	100	203	300	12000	117.7
F350-550	550	380	100	203	300	12000	117.7
F350-600	600	405	100	203	300	14000	137.3