

## 362 ADJUSTABLE SUPPORT ROLLER CHAIR

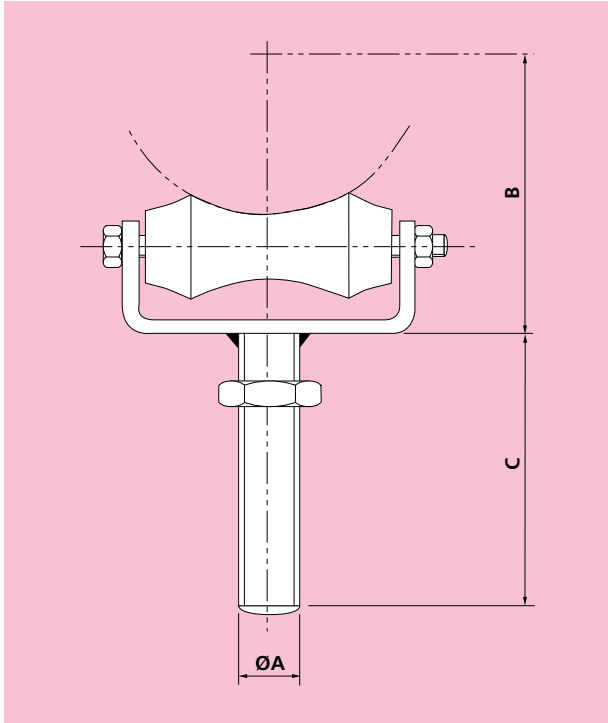

Material: Cast Iron and Carbon Steel

PART No.	PIPE SIZE	A	B	C	STEEL SIZE	SWL	
						kgf	kN
F362-25	25	12	59	150	25x5	275	2.7
F362-32	32	12	67	150	25x5	275	2.7
F362-40	40	12	70	150	25x5	275	2.7
F362-50	50	12	78	150	30x6	275	2.7
F362-65	65	12	90	150	30x6	300	2.9
F362-80	80	12	100	150	40x6	318	3.1
F362-100	100	16	125	150	40x6	340	3.3
F362-125	125	16	145	150	50x10	340	3.3
F362-150	150	20	165	150	50x10	485	4.7
F362-200	200	20	200	150	50x12	600	5.9
F362-250	250	24	240	150	65x12	785	7.7
F362-300	300	24	280	150	65x12	1088	10.7
F362-350	350	30	310	150	80x12	1400	13.7
F362-400	400	30	343	150	80x12	1800	17.6
F362-450	450	30	370	150	80x12	1900	18.6
F362-500	500	36	410	150	100x12	2000	19.6
F362-600	600	36	500	150	100x16	2800	27.5