

SPRING HANGER

Figure 399

Designed to provide an economical means to support low pipe loads with vertical movement. In selecting the correct spring size consideration should be given to weight of pipe to be supported and its contents, insulation, concentrated loads, as well as the anticipated deflection. Please see our Engineered Spring Catalog for units requiring higher loads and/or greater movements.

Material: Carbon Steel.

Finish: Plain, Painted, Electro-Galvanized.

Ordering: Specify spring size, figure number, and finish.
For Metric applications specify Figure M399.

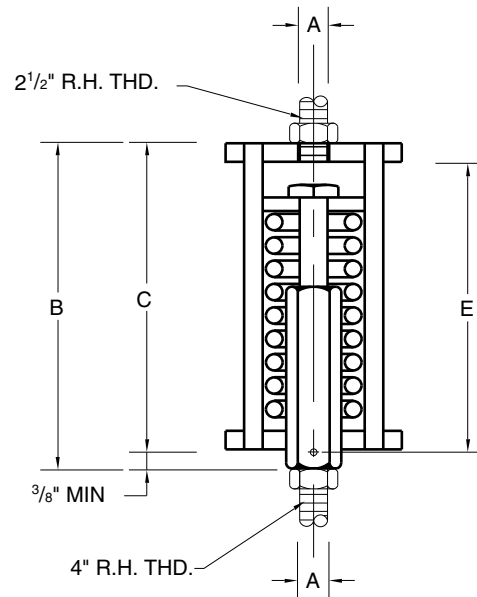

FIGURE 399 – SPRING HANGER

| SPRING NO. | MAX. LOAD | MAX. DEFLECTION | SPRING DEFLECTION | A | B | | C | E | WEIGHT EACH |
|------------|-----------|-----------------|-------------------|-----|-------|--------|-------|-------|-------------|
| | | | | | MIN. | MAX. | | | |
| 1 | 52 | 2 | 26 lbs./in. | 3/8 | 4 1/2 | 6 1/2 | 4 3/4 | 3 3/4 | 1.60 |
| 1 | 231 | 51 | 4.5 N/mm | M10 | 114 | 165 | 105 | 95 | 0.73 |
| 2 | 115 | 1 1/4 | 66 lbs./in. | 3/8 | 4 1/2 | 6 1/4 | 4 3/4 | 3 3/4 | 2.38 |
| 2 | 512 | 44 | 11.6 N/mm | M10 | 114 | 159 | 105 | 95 | 1.08 |
| 3 | 163 | 1 1/2 | 87 lbs./in. | 1/2 | 5 3/4 | 7 3/4 | 5 1/2 | 5 | 2.87 |
| 3 | 725 | 48 | 15.1 N/mm | M12 | 149 | 197 | 140 | 127 | 1.30 |
| 4 | 266 | 1 3/4 | 152 lbs./in. | 1/2 | 5 3/4 | 7 3/4 | 5 1/2 | 5 | 3.50 |
| 4 | 1183 | 44 | 26.8 N/mm | M12 | 149 | 194 | 140 | 127 | 1.59 |
| 5 | 400 | 2 | 200 lbs./in. | 3/8 | 6 3/4 | 8 3/4 | 6 3/4 | 5 3/4 | 6.80 |
| 5 | 1779 | 51 | 34.9 N/mm | M16 | 171 | 222 | 162 | 146 | 3.08 |
| 6 | 600 | 2 1/2 | 240 lbs./in. | 3/4 | 8 3/4 | 10 3/4 | 8 | 7 3/4 | 9.82 |
| 6 | 2669 | 64 | 41.7 N/mm | M20 | 213 | 276 | 203 | 187 | 4.45 |

| DIMENSIONS | TEMPERATURE | LOADS | WEIGHT |
|-------------|-------------|---------|-----------|
| INCHES | FAHRENHEIT | POUNDS | POUNDS |
| MILLIMETERS | CELSIUS | NEWTONS | KILOGRAMS |