

## 361 PIPE ROLLER

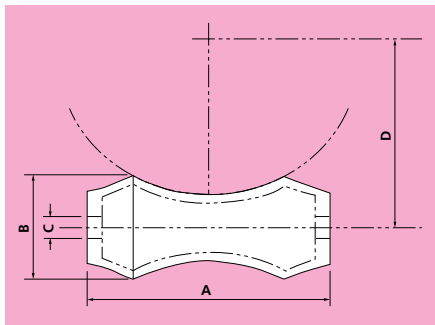

Material: Cast Iron

PART No.	PIPE SIZE	A	B	C	D	LOAD CAPACITY	
						lbs	kip
F361-25	1	0.99	0.79	0.48	1.07	606	0.61
F361-32	1 1/4	1.46	0.83	0.48	1.26	606	0.61
F361-40	1 1/2	1.58	0.87	0.48	1.38	606	0.61
F361-50	2	1.74	0.95	0.48	1.62	606	0.61
F361-65	2 1/2	2.37	1.15	0.56	1.93	661	0.66
F361-80	3	3.71	1.38	0.56	2.25	701	0.7
F361-100	4	3.71	1.38	0.56	2.8	749	0.75
F361-125	5	5.75	1.93	0.79	3.43	749	0.75
F361-150	6	5.75	1.93	0.79	4.06	1069	1.07
F361-200	8	8.98	2.72	0.95	5.12	1322	1.32
F361-250	10	11.03	3.35	1.07	6.26	1730	1.73
F361-300	12	13	3.94	1.07	7.45	2398	2.4
F361-350	14	14.22	4.73	1.07	8.39	3086	3.09
F361-400	16	16.23	5.12	1.07	9.45	3968	3.97
F361-450	18	18.23	5.44	1.07	10.52	4188	4.19
F361-500	20	20.24	5.99	1.3	11.62	4409	4.41
F361-600	24	24.22	7.21	1.3	14.38	6172	6.17
F361-750	30	30.32	8.63	2.01	17.45	7275	7.28
F361-900	36	35.99	9.89	2.6	20.52	11023	11.02